

BUTLER

Assembly Instructions
Style Number 3020

SPECIALTY COMPANY

8200 SOUTH CHICAGO AVE., CHICAGO, IL 60617

PACKAGED

- | | |
|-------------------------|-------------------------|
| (A) 8 -5/16 Flat washer | (B) 8 -5/16 Lock Washer |
| (C) 8 -5/16 Bolt | (D) 1 -Allen Wrench |
| (E) 4-1/4 Bolt | (F) 4-1/4 Lock Washer |
| (G) 4-1/4 Flat washers | (H) 1-Top |
| (I) 4-Leg | (J) 1-Shelf |

Read all instructions before starting assembly.

Step #1 Check all the components listed in "packaged" are included. Carefully put the top (H) on a flat and protected work surface being careful not to scratch the finish.

Step #2 Put the legs (I) in the top bottom (H) by using bolt (C), lock washer (B), flat washer (A) & allen wrench (D) to tighten the legs. See Diagram 1.

Step #3 Put the shelf (J) on, then turn the bolt hole of L shape metal bracket to aim the hole on leg (I) to tighten the shelf (J) by using bolt (E), lock washer (F), flat washer (G) and allen Wrench(D). See diagram 2.

Step #4 Turn the assembled unit over.

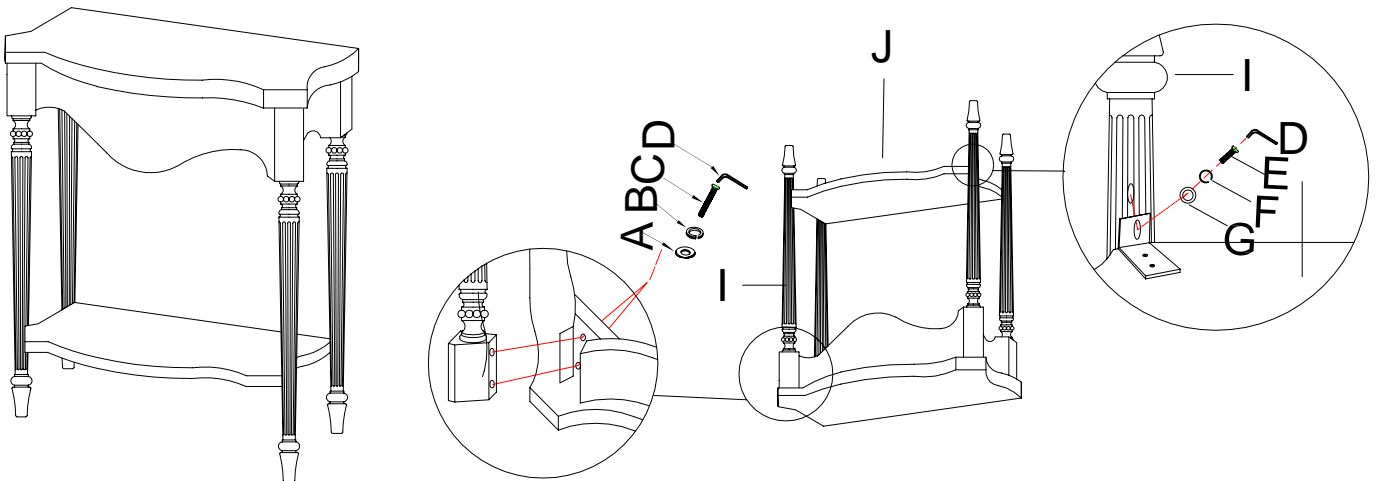

(* Caution: DO NOT OVERTIGHTEN.

In any correspondence regarding this product, please include the complete Butler identification number located on the underside of the product.

We hope this Console Table will be a useful and decorative addition to your home for years to come.

Copyright © Butler Specialty Company 04/2010